

FX-9707 Heavy-duty soldering iron



Tip not included



Tip not included

FX9707-81

Handpiece (FX-9707), Instruction manual

Conversion kit FX9707-811

Handpiece (FX-9707), Iron holder (FH-220, with cleaning sponge and wire), Instruction manual

■ Specifications

Model No.	FX-9707
Power consumption	200 W (24V)
Temperature range	50 to 500°C
Tip to ground resistance	< 2 Ω
Tip to ground potential	< 2 mV
Heating element	Composite heater
Cord length	1.2 m
Total length (w/o cord)	222 mm (with T53-D24 tip)
Weight (w/o cord)	41 g (with T53-D24 tip)

FX-9708 Heavy-duty N₂ soldering iron



Tip not included



Tip not included

FX9708-81

Handpiece (FX-9708), Instruction manual

Conversion kit FX9708-811

Handpiece (FX-9708), Iron holder (FH-220, with cleaning sponge and wire), Instruction manual

■ Specifications

Model No.	FX-9708
Power consumption	200 W (24V)
Temperature range	50 to 500°C
Tip to ground resistance	< 2 Ω
Tip to ground potential	< 2 mV
Heating element	Composite heater
Cord length	1.2 m
Total length (w/o cord)	231 mm (with T53-D24 tip)
Weight (w/o cord)	47 g (with T53-D24 tip and nozzle assembly C)

T53 series soldering tip

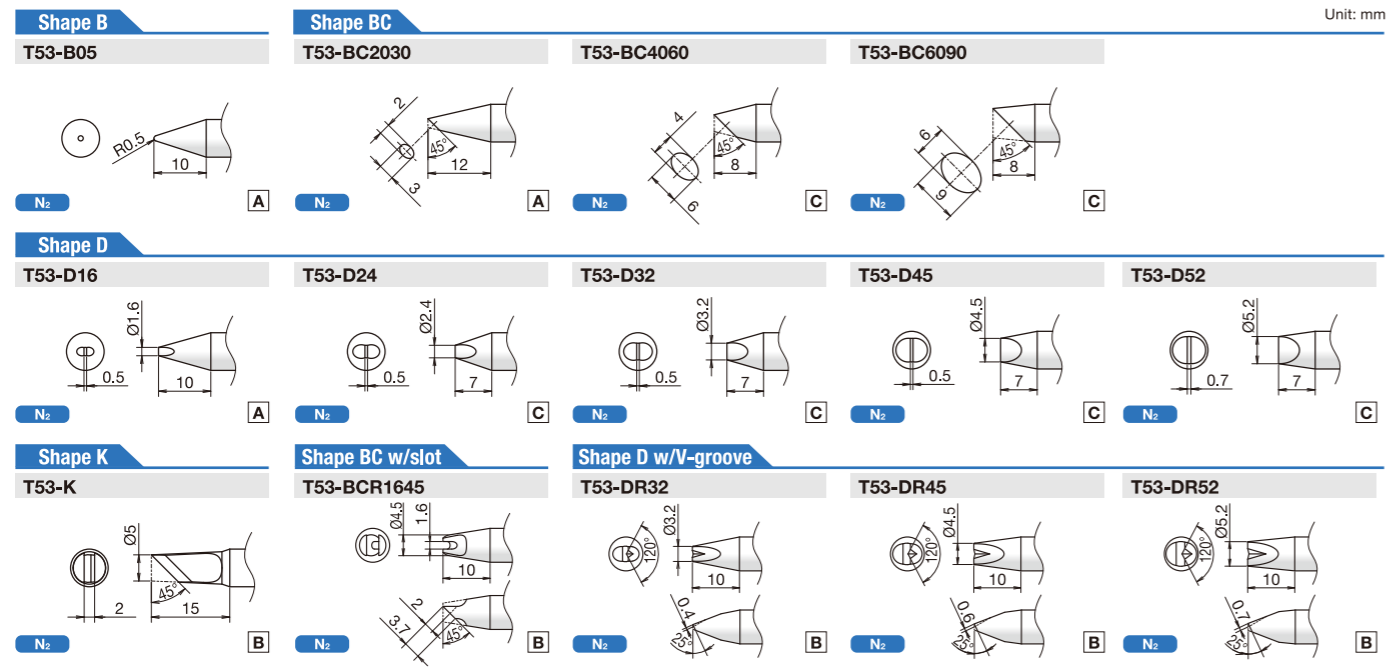

Use an FX-9708 Heavy-duty N₂ soldering iron with a proper nozzle assembly for the tip.

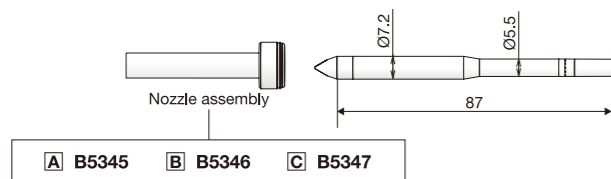

Setup with N₂ system



HEAD OFFICE

4-5, SHIOKUSA 2-CHOME, NANIWA-KU, OSAKA, 556-0024 JAPAN
TEL:+81-6-6561-3225 FAX:+81-6-6561-8466
<https://www.hakko.com> E-mail:sales@hakko.com

OVERSEAS AFFILIATES
U.S.A.
AMERICAN HAKKO PRODUCTS, INC.
28920 AVENUE WILLIAMS VALENCIA, CA 91355, U.S.A.
TEL: (661) 294-0090 FAX: (661) 294-0096
Toll Free (800)88-HAKKO
<https://www.HakkoUSA.com>
E-mail:Support@HakkoUSA.com

HONG KONG
HAKKO DEVELOPMENT CO., LTD.
ROOM 1504, EASTERN HARBOUR CENTRE,
28 HOI CHAK STREET, QUARRY BAY, HONG KONG.
TEL: 2811-5588 FAX: 2590-0217
<https://www.hakko.com.cn>
E-mail:info@hakko.com.hk

SINGAPORE
HAKKO PRODUCTS PTE LTD
1, GENTING LINK #02-04
PERFECT ONE, SINGAPORE 349518
TEL: 6748-2277 FAX: 6744-0033
<https://www.hakko.com.sg>
E-mail:sales@hakko.com.sg

CA00574EaYa002 2024.02

Please access the web address below for other distributors.
<https://www.hakko.com>

Specifications and design are subject to change without notice.
Copyright HAKKO Corporation. All right reserved.

Combination table for station, handpiece, iron holder, and soldering tip

Station

Handpiece

Iron holder

Soldering tip



FX-971 100 W 1-port station



FX-971

Station, Handpiece (FX-9701), Iron holder (FH-215, with cleaning sponge and wire), USB cable, Power cord, Instruction manual

The dedicated software is available for download on HAKKO website.

■ Specifications

Model No.	FX-971
Power consumption	100 W
Temperature range	50 to 450°C
Temperature stability	±3°C (At idle temperature)

Station

Output	AC 24 V
Dimensions	When tilted: 93 (W) x 126 (H) x 133 (D) mm When not tilted: 93 (W) x 126 (H) x 123 (D) mm
Weight	1.2 kg

Handpiece

Power consumption	95 W (24V)
Tip to ground resistance	< 2 Ω
Tip to ground potential	< 2 mV
Heating element	Composite heater
Cord length	1.2 m
Total length (w/o cord)	206 mm (with T39-D24 tip)
Weight (w/o cord)	31 g (with T39-D24 tip)

FX-9701 Soldering iron



FX9701-81

Handpiece (FX-9701)

■ Specifications

Model No.	FX-9701
Power consumption	95 W (24V)
Temperature range	50 to 450°C
Tip to ground resistance	< 2 Ω
Tip to ground potential	< 2 mV
Heating element	Composite heater
Cord length	1.2 m
Total length (w/o cord)	206 mm (with T39-D24 tip)
Weight (w/o cord)	31 g (with T39-D24 tip)



Conversion kit FX9701-811

Handpiece (FX-9701), Iron holder (FH-215, with cleaning sponge and wire)

FX-972 200 W 2-port station



FX-972

Station, Handpiece (FX-9701), Iron holder (FH-215, with cleaning sponge and wire), Color band [qty 2], USB cable, Power cord, Instruction manual

The dedicated software is available for download on HAKKO website.

■ Specifications

Model No.	FX-972
Power consumption	200 W
Temperature range	50 to 450°C With heavy-duty soldering iron connected: 50 to 500°C
Temperature stability	±3°C (At idle temperature) With heavy-duty soldering iron connected: ±5°C (At idle temperature)

Station

Output	AC 24 V
Dimensions	When tilted: 126 (W) x 151 (H) x 149 (D) mm When not tilted: 126 (W) x 151 (H) x 136 (D) mm
Weight	2.8 kg

Handpiece

Power consumption	95 W (24V)
Tip to ground resistance	< 2 Ω
Tip to ground potential	< 2 mV
Heating element	Composite heater
Cord length	1.2 m
Total length (w/o cord)	206 mm (with T39-D24 tip)
Weight (w/o cord)	31 g (with T39-D24 tip)

FX-9702 N₂ soldering iron



FX9702-81

Handpiece (FX-9702), Instruction manual

■ Specifications

Model No.	FX-9702
Power consumption	95 W (24V)
Temperature range	50 to 450°C
Tip to ground resistance	< 2 Ω
Tip to ground potential	< 2 mV
Heating element	Composite heater
Cord length	1.2 m
Total length (w/o cord)	227 mm (with T39-D24 tip)
Weight (w/o cord)	49 g (with T39-D24 tip and nozzle assembly D)



Conversion kit FX9702-811

Handpiece (FX-9702), Iron holder (FH-215, with cleaning sponge and wire), Instruction manual

T39 series soldering tip

Shape B				
T39-B02	T39-B05	T39-B07	T39-BL02	T39-BLL02
N ₂ F	N ₂ G	N ₂ C	N ₂ K	N ₂ I
T39-BS02	T39-BS03			
Shape BC				
T39-BC1020	T39-BC1530	T39-BC2040	T39-BC2535	T39-BC3065
N ₂ I			N ₂ H	
T39-BC3545	T39-BCF1020*	T39-BCF2535*	T39-BCF3545*	
N ₂ E	N ₂ I	N ₂ H	N ₂ E	
Shape BCM				
T39-BCM2535	T39-BCM3545			
N ₂ H	N ₂ E			
Shape C				
T39-C1020	T39-C1025	T39-C4055	T39-CF4055*	
N ₂ J	N ₂ J	N ₂ E	N ₂ E	
Shape D				
T39-D08	T39-D12	T39-D16	T39-D24	T39-D32
N ₂ G	N ₂ G	N ₂ G	N ₂ D	N ₂ D
T39-D4	T39-D52	T39-DL32	T39-DL4	T39-DL52
N ₂ B	N ₂ B			
T39-DLS15	T39-DS24	T39-DS32	T39-DS4	T39-DS52
	N ₂ C	N ₂ C	N ₂ C	N ₂ C

*Pre-tinned on cut surface only

Shape I				
T39-I02	T39-IL02	T39-ILS015		
N ₂ J	N ₂ K	N ₂ K		
Shape J				
T39-J02	T39-JL02	T39-JS02	T39-JD08	T39-JD14
N ₂ I				
T39-JD16				
Shape K				
T39-K	T39-KF	T39-KL	T39-KR	T39-KU
N ₂ A	N ₂ A	N ₂ B	N ₂ B	N ₂ F
with slot				
T39-BCR1235	with V-groove			
	T39-BCR12	T39-BCR16	T39-BCR24	T39-BCR32
N ₂ D	N ₂ I	N ₂ I	N ₂ H	N ₂ E
T39-BCR4	T39-BCR52	T39-DR12	T39-DR16	T39-DR24
N ₂ B	N ₂ B	N ₂ G	N ₂ G	N ₂ D
T39-DR32	T39-DR4	T39-DR52		
N ₂ D	N ₂ D	N ₂ B		
Spatula				
T39-SP104	T39-SP157	T39-SP212		

FX-9702 N₂ soldering iron can be used with soldering tips with N₂ mark. Use a tip with an applicable nozzle assembly.

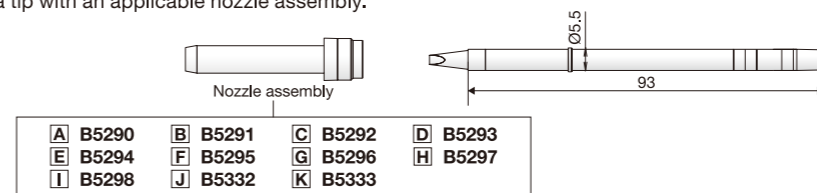

Setup with N₂ system

FX-9703 Micro soldering iron



FX9703-81

Handpiece (FX-9703), Instruction manual

■ Specifications

Model No.	FX-9703
Power consumption	70 W (24V)
Temperature range	50 to 450°C
Tip to ground resistance	< 2 Ω
Tip to ground potential	< 2 mV
Heating element	Composite heater
Cord length	1.2 m
Total length (w/o cord)	174 mm (with T50-D1 tip)
Weight (w/o cord)	15 g (with T50-D1 tip)

Conversion kit FX9703-811

Handpiece (FX-9703), Iron holder (FH-215, with cleaning sponge and brush), Instruction manual

FX-9704 Micro N₂ soldering iron



FX9704-81

Handpiece (FX-9704), Instruction manual

■ Specifications

Model No.	FX-9704
Power consumption	70 W (24V)
Temperature range	50 to 450°C
Tip to ground resistance	< 2 Ω
Tip to ground potential	< 2 mV
Heating element	Composite heater
Cord length	1.2 m
Total length (w/o cord)	196 mm (with T50-D1 tip)
Weight (w/o cord)	35 g (with T50-D1 tip and nozzle assembly A)

Conversion kit FX9704-811

Handpiece (FX-9704), Iron holder (FH-215, with cleaning sponge and brush), Instruction manual

T50 series soldering tip

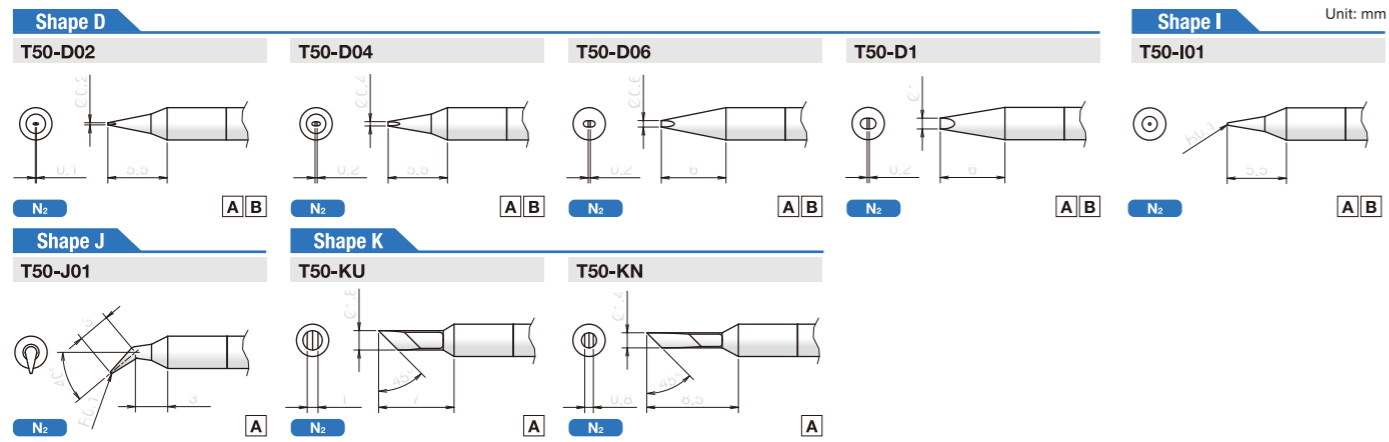

Use an FX-9704 Micro N₂ soldering iron with a proper nozzle assembly for the tip.

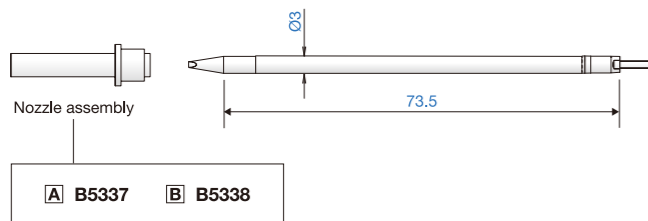

□ Check out the difference between nozzle assemblies A and B with the tip T50-D06.

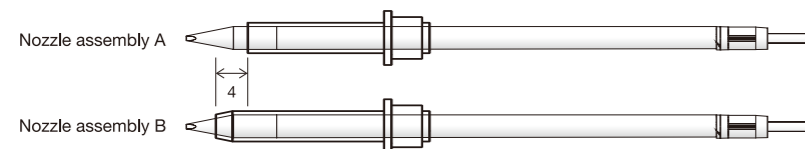

Set the nozzle assembly A when using the tip horizontally or the nozzle assembly B interferes with surrounding components.

FX-9705 Hot tweezers



FX9705-81

Handpiece (FX-9705), Instruction manual

■ Specifications

Model No.	FX-9705
Power consumption	190 W (24V)
Temperature range	50 to 450°C
Tip to ground resistance	< 2 Ω
Tip to ground potential	< 2 mV
Heating element	Composite heater
Cord length	1.2 m
Total length (w/o cord)	146 mm (with T51-L16 tip)
Weight (w/o cord)	55 g (with T51-L16 tip)

Conversion kit FX9705-811

Handpiece (FX-9705), Iron holder (FH-220, with cleaning sponge and wire), Instruction manual

FX-9706 Micro hot tweezers



FX9706-81

Handpiece (FX-9706), Instruction manual

■ Specifications

Model No.	FX-9706
Power consumption	140 W (24V)
Temperature range	50 to 450°C
Tip to ground resistance	< 2 Ω
Tip to ground potential	< 2 mV
Heating element	Composite heater
Cord length	1.2 m
Total length (w/o cord)	130 mm (with T52-I015 tip)
Weight (w/o cord)	33 g (with T52-I015 tip)

Conversion kit FX9706-811

Handpiece (FX-9706), Iron holder (FH-215, with cleaning sponge and brush), Instruction manual

T51 series soldering tip (set of 2)

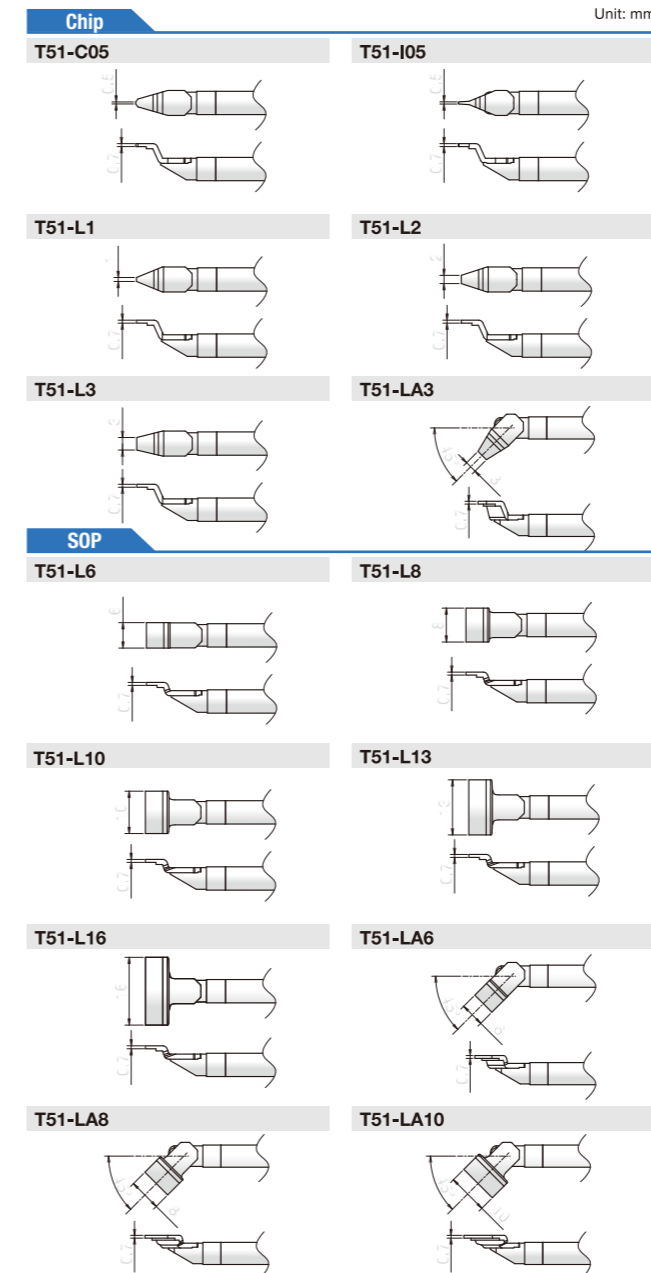

T52 series soldering tip (set of 2)

